

## INDUSTRIAL DIESEL ENGINE

### KUBOTA 03-M-SERIES (4-cylinder)

# V2403-M-T-E3B



### RATED POWER

44.0 kW/2700 rpm

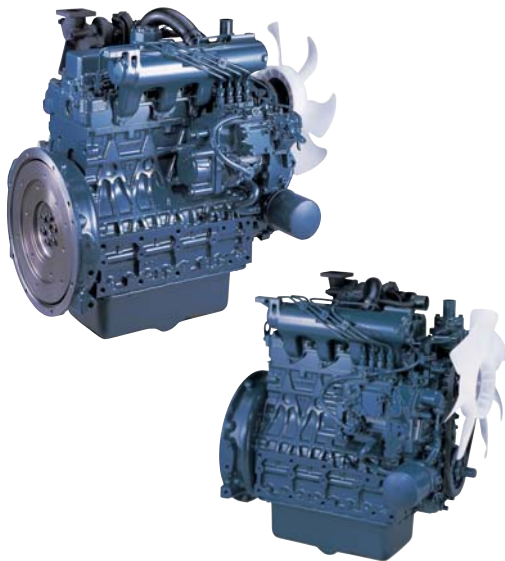

### PERFORMANCE CURVE

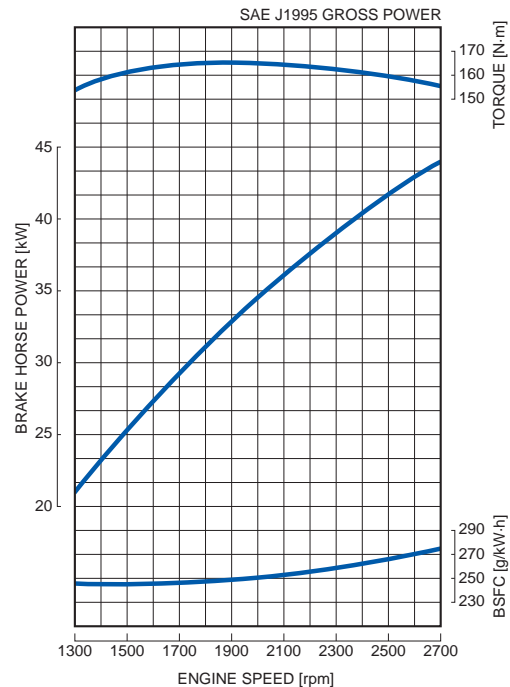

### FEATURES with BENEFITS

#### Emissions

- The V2403-M Turbocharged engine complies with EPA Interim Tier 4 (Option1) emissions regulations, which are the most stringent in this class. This engine also complies with EU Stage 3A requirements. It offers the benefit of one year longer validity than Tier 3. Therefore, this engine is good through the end of 2012 in both the North American and European markets, which would save engineering resources for the future emission regulations.
- Utilizing the low NOx characteristics of IDI engines, the V2403-M-T engine complies with the latest emissions regulations without any devices.

#### Durable Power

- The Kubota V2403-M-T engine is a new high power density engine that delivers the highest output within the Kubota 03-M-Series.
- By expanding the bore and stroke, Kubota increased engine displacement. The cooling water passages between the cylinder bores, using Kubota's original casting technology as a countermeasure against high heat load provides both superior endurance and reliable engine characteristics.
- With numerous features such as a built-in solenoid, low fan position, and single side serviceability, this engine offers excellent performance characteristics and application flexibility.

#### Clean and Quiet Power

- Kubota's original E-TVCS (Three Vortex Combustion System) has been improved. The airflow, combustion chamber and piston recess were optimized to provide a 25% lower particulate matter (PM) level, resulting in a better condition compared to engines that only meet EPA Tier 3 regulations in this class.
- The half-float valve cover and MoS<sub>2</sub> coated pistons, which reduce noise levels and provide reduced transmitted vibration from the valve area for better noise characteristics are also adopted.

#### Option

- The Kubota 03-M-Series engines offer side power take-off(PTO), in response to the trend of increasing hydraulic control devices in industrial machines. It is possible to install a hydraulic pump at two side PTO locations.

## GENERAL SPECIFICATION

Model		<b>V2403-M-T-E3B</b>
Emission Regulation		Interim Tier 4 / Stage 3A
Type		Vertical 4-cycle Liquid Cooled Diesel
Number of Cylinders		4
Bore	mm (in)	87 (3.43)
Stroke	mm (in)	102.4 (4.03)
Displacement	L (cu.in)	2.434 (148.5)
Combustion System		Indirect Injection
Intake System		Turbocharged
Maximum Speed	rpm	2700
Output: SAE J1995 Gross Power	kW	44.0
	hp	59.0
	ps	59.8
Direction of Rotation		Counterclockwise Viewed on Flywheel
Oil Pan Capacity	L (gal)	9.5 (2.51)
Starter Capacity	V-kW	12-2.0
Alternator Capacity	V-A	12-40
Length	mm (in)	670.9 (26.4)
Width	mm (in)	499.0 (19.6)
Height (1)	mm (in)	724.6 (28.5)
Height (2)	mm (in)	265.5 (10.5)
Dry Weight	kg (lb)	188.0 (414.5)

\*Specification is subject to change without notice.

\*Dry weight is according to Kubota's standard specification.  
When specification varies, the weight will vary accordingly.

\*SAE J1995 Gross Power: 1-hour rating based on engine without cooling fan, air cleaner and muffler, with alternator.

## DIMENSIONS

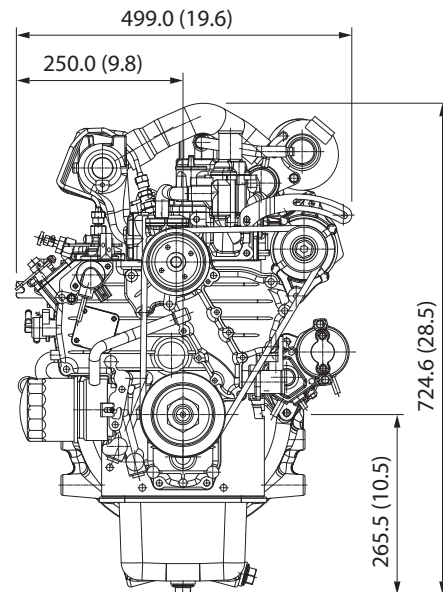
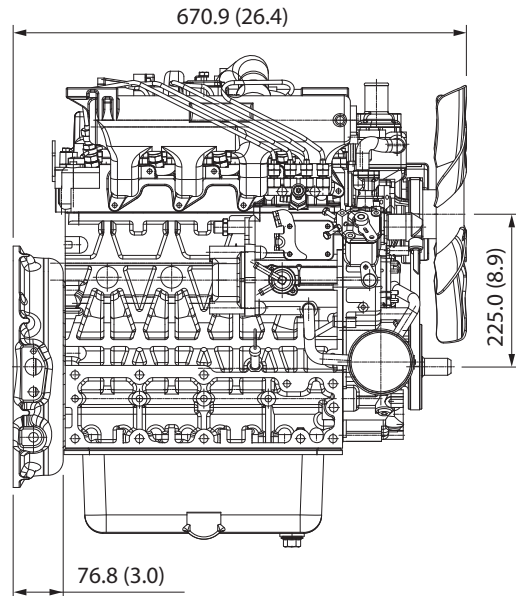

**Kubota Corporation**

2-47, Shikitsuhigashi 1-chome, Naniwa-ku, Osaka, 556-8601 Japan  
 Fax: +81 (0) 6 6648 /35 21  
<http://www.engine.kubota.ne.jp>

**Kubota (Deutschland) GmbH**

Senefelder Str. 3-5  
 63110 Rodgau

Phone: +49 (0) 6106 / 873 - 113

Fax: +49 (0) 6106 / 873 - 196

eMail: [motoren@kubota.de](mailto:motoren@kubota.de)

homepage: [www.kubota.de](http://www.kubota.de)