

INDUSTRIAL DIESEL ENGINE

KUBOTA BG-SERIES (3-cylinder)

D1703-M-BG

RATED POWER

15.0 kW/1500 rpm



FEATURES with BENEFITS

Emissions

- Kubota BG engines are designed for generator applications to be operated at 1500 rpm or 1800 rpm only. The integrated electronic governor allows a highly precise engine speed control at a minimum noise level.

E-TVCS (Three Vortex Combustion System)

- Kubota's highly efficient E-TVCS System (Three Vortex Combustion System), located in a specially designed piston with a valve recess and a fanshaped concave, produces an ideal air/fuel mixture by creating three vortices in the combustion chamber. This results in better cross flow of air and exhaust gas, lower air intake temperature and improved combustion efficiency.

Super Glow System

- The Super Glow System, not necessary in temperatures above 5°C, comes as standard equipment to start the engine in cold temperatures. For example, at -20°C (-4°F), the engine will start only 10 seconds of preheating time.

Cleaner Exhaust Engines

- One of Kubota's major commitments has always been the development of a cleaner exhaust engine. Kubota was the first engine manufacturer to pass the U.S. CARB ULGE emission regulations for engines under 19 kW. Kubota produced engines that have been certified, or are now currently in compliance with all emission regulations around the world.

GENERAL SPECIFICATION

Model		D1703-M-E3BG
Emission Regulation		no EG regulation
Type		Vertical 4-cycle Liquid Cooled Diesel
Number of Cylinders		3
Bore	mm (in)	87.0 (3.43)
Stroke	mm (in)	92.4 (3.64)
Displacement	L (cu.in)	1.647 (100.5)
Combustion System		Indirect Injection
Intake System		Naturally Aspirated
Maximum Speed	rpm	1500
	kW	15.0
Output: Stand-by ISO 3046 IC15N	hp	20.1
	ps	20.4
	kW	12.8
Output: Continuous ISO 3046 IC15N	hp	17.2
	ps	17.4
	kW	12.8
Direction of Rotation		Counterclockwise viewed on Flywheel
Oil Pan Capacity	L (gal)	5.6 (1.48)
Starter Capacity	V-kW	12-1.4
Alternator Capacity	V-A	12-40
Length	mm (in)	605.6 (23.8)
Width	mm (in)	490.0 (19.3)
Height (1)	mm (in)	643.0 (25.3)
Height (2)	mm (in)	229.3 (9.0)
Dry Weight	kg (lb)	168.0 (370.4)

*Specification is subject to change without notice.

*Dry weight is according to Kubota's standard specification.

When specification varies, the weight will vary accordingly.

DIMENSIONS

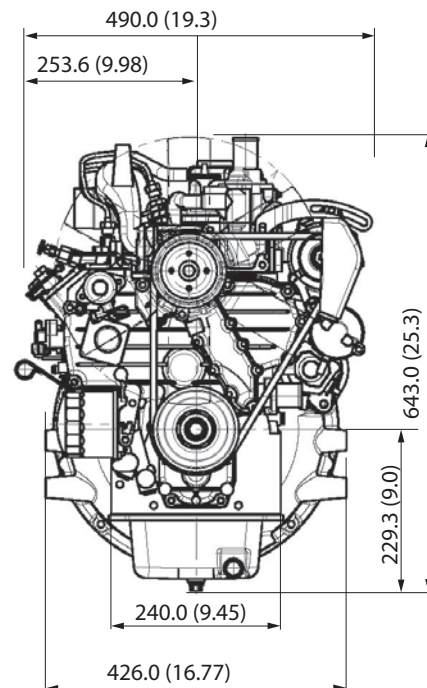
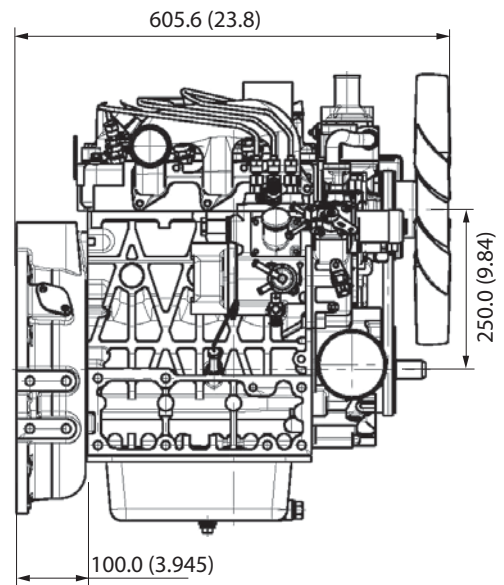

Kubota Corporation

2-47, Shikitsuhigashi 1-chome, Naniwa-ku, Osaka, 556-8601 Japan
 Fax: +81 (0) 6 6648 /35 21
<http://www.engine.kubota.ne.jp>

Kubota (Deutschland) GmbH

Senefelder Str. 3-5
 63110 Rodgau

Phone: +49 (0) 6106 / 873 - 113
 Fax: +49 (0) 6106 / 873 - 196
 eMail: motoren@kubota.de
 homepage: www.kubota-motoren.de